

TW-5223

INTERCHANGEABLE PRODUCTS:

- Rice Lake RL75223
- Revere 5223
- Thurman TSC800
- Celtron HED
- Unibrige DL9000

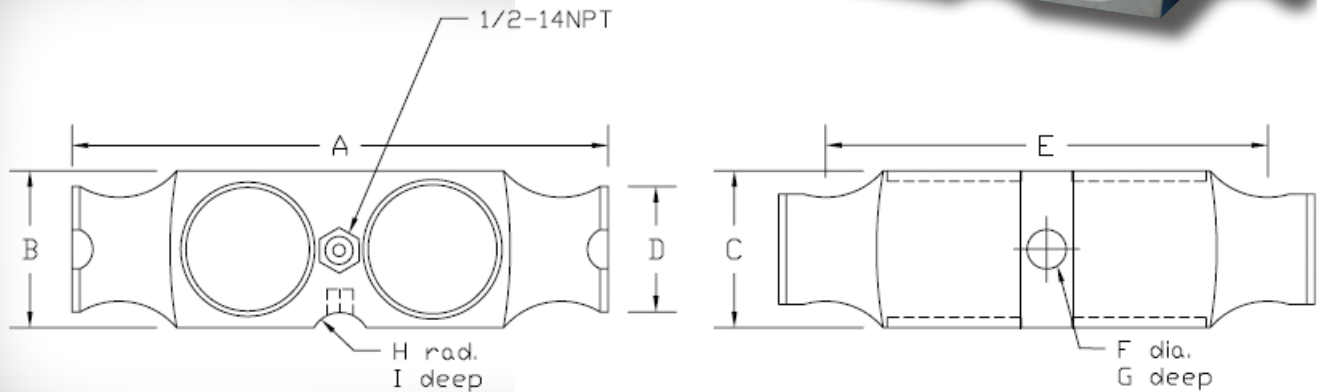

DIMENSIONS

Rated Capacity	A	B	C	D	E	F	G	H	I
40K- 125K	10.25	3.00	3.00	2.40	8.50	0.75	0.78	1.00	0.28

SPECIFICATIONS

Full Scale Output: 3.0 mV/V
 Temperature: Compensated range
 -14 deg. F to 104 deg. F
 -10 deg. C to 40 deg. C
 Safe Overload: 150% Full Scale
 Rated Excitation: 10-15V DC
 Bridge Resistance: 700 ohms
 Zero Balance: +/- 1.00 F.S.

Insulation Resistance: >5000megohms
 Cable Length: 50ft./16m
 Cable Coloring: Green...+Excitation
 Black...-Excitation
 White...+Signal
 Red...-Signal
 Warranty: 1-year limited warranty

TECHWEIGH